

MTX9509 and MRX9509

12 Channel Parallel Optical TX and RX Modules,
1.25 Gbps per Channel

Applications

- Optical backplanes
- Ganged serial links
- Very Short Reach SONET
- Logic-logic data links
- Board-to-board and shelf-to-shelf

Features

- Single +3.3V power supply
- Power Consumption 1.5 Watts typ.
- 100-pin matrix array electrical connector
- MPO Optical connector
- CML data path inputs and outputs, with support for both AC and DC coupled IO
- Zero to 80 °C case temperature range

Compliance

- Fits in SNAP12 MSA sockets
- Eye safety: Class 1M laser product per EN609825-1 and FDA/CDRH
- Electromagnetic Emissions: FCC part 15 - Class B (Residential), EN55022 (Formerly CISPR 22)
- Electromagnetic Immunity: EN61000-4-3, GR-1089-CORE Section 3.3

The MTX9509 and MRX9509 are cost-effective high-speed transmitter (TX) and receiver (RX) modules for use as parallel optical data communication links. The modules perform logic-to-light and light-to-logic conversions for data transmission over multi-mode fiber ribbon cable, at a wavelength of 850 nm.

The transmitter module uses a 1x12 oxide-confined VCSEL array. The receiver uses a high-speed photodiode array.

For optical cable connections, both modules use industry standard IEC 1754-7 MPO connector receptacles. For electrical connections, both modules use widely accepted 100 pin matrix-array connectors.

Mechanical Interface

Package Dimensions

A common package format is used for both the MTX9509 transmitter and MRX9509 receiver modules; see image on cover page. The only difference between the modules is the position of the electrical receptacle relative to the mounting feet.

MODULE DIMENSIONS

Key	Value mm	Tolerance mm
A1	35.37	±0.25
B1	16.75	±0.25
C1	14.50	±0.25
D1	3.10	±0.25
E1	12.12	±0.25
F1	7.43	±0.25
G1	12.50	±0.25
H1	4.44	±0.25
J1	0.381	±0.12
K1	0.76	±0.12
L1	31.75	±0.50
M1	30.23	±0.12
N1	13.72	±0.12
P1	1.14	±0.12
R1	19.43	±0.12
S1	∅3.80	±0.25
T1	THREAD	—
U1	16.89	±0.12
V1	∅1.30	±0.12
W1	∅2.50	±0.25
X1	28.42	±0.5
Y1	7.80	±0.5
Z1	41.00	±0.5
AE1	8.38	±0.25
AF1	2.30	±0.01
AH1	7.50	±0.1

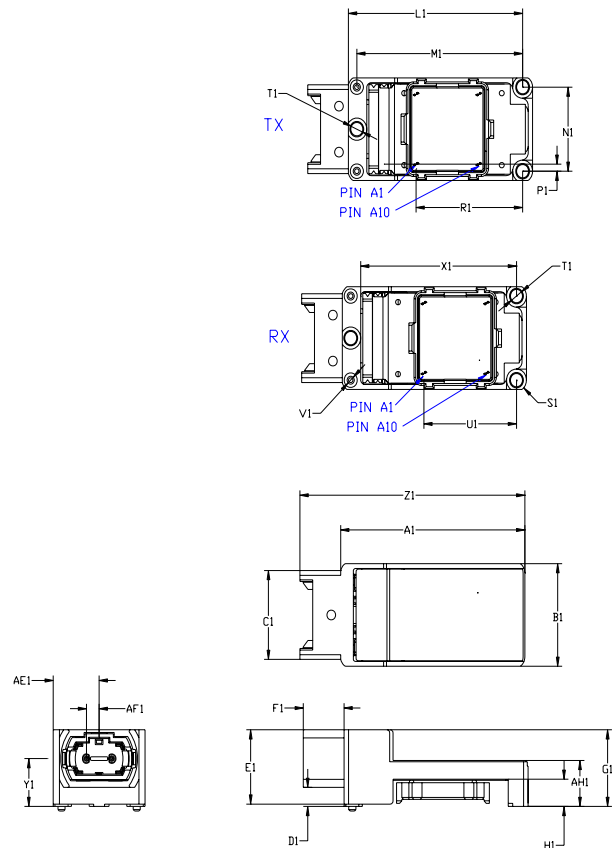

MODULE DIMENSIONS

Tolerancing per ASME Y14.5M-1994. All dimensions are in mm.

Product Disclaimer

EMCORE reserves the right to alter product specifications, features, capabilities, and functions or to discontinue products at any time without notice.

Copyright © 2006 EMCORE Corporation

Ordering Information

MTX9510-FB 12 Channel Parallel Optical TX Module – 1.25 Gbps per Channel – with Flat Base for customer-provided heat sink

MRX9510-FB 12 Channel Parallel Optical RX Module – 1.25 Gbps per Channel – with Flat Base for customer-provided heat sink

MTX9510-HS 12 Channel Parallel Optical TX Module – 1.25 Gbps per Channel – with heat sink

MRX9510-HS 12 Channel Parallel Optical RX Module – 1.25 Gbps per Channel – with heat sink

Contact Information

For more information on this application note, related application notes or related products please contact:

Sales — EMCORE Fiber Optics Division
fiberoptics@emcore.com
EMCORE Corporation
1600 Eubank Blvd SE
Albuquerque, New Mexico 87123
Tel: (505) 559-2600
Fax: (505) 323-3430

Product Disclaimer

EMCORE reserves the right to alter product specifications, features, capabilities, and functions or to discontinue products at any time without notice.

Copyright © 2006 EMCORE Corporation